



WING ES 26-12

WETAC ENERGY SOLUTIONS



WING BATTERIES - ES 26-12

Stationary, maintenance-free, sealed lead battery 12V – 26Ah

Designlife

6-9 Years

WING ES Batteries utilize superior cast grid plates with electrolyte absorbed in a glass fiber separator (AGM). The features of the ES range make them extremely versatile and adaptable for use in the fields of security lighting, UPS systems, IT / data centers, telecommunications applications etc.

Electrical specifications

Nominal Voltage:	12 V
Capacity 25°C to 1.8V/C (20 h):	26,0 Ah
Capacity 25°C to 1.8V/C (10 h):	23,7 Ah
Capacity 25°C to 1.8V/C (8 h):	22,1 Ah
Capacity 25°C to 1.8V/C (3 h):	18,9 Ah
Capacity 25°C to 1.8V/C (1 h):	15,5 Ah
Self discharge @ 25°C per month:	≈ 2,5 - 3%
Internal Resistance fully charged:	≈ 12 mΩ
Max. current (charging) @ 25°C:	7,8 A
Max. current (discharging) @ 25°C (5 Sec.):	390 A
Charge Voltage (Float) @ 25°C (-18mV/°C):	2,27-2,29 V/C
Charge Voltage (Cyclic) @ 25°C (-30mV/°C):	2,41-2,48 V/C

Design features

- Life time 6-9 Years
- High rate discharge optimised
- Advanced Lead-calcium cast grid design
- Enhanced AGM separators for improved electrolyte distribution
- Capacity range: 1,2 Ah to 65 Ah
- ES 12V Batteries with VdS standard: 1,2 | 2,3 | 3,2 | 7 | 12 | 18 | 26 | 40 | 65 Ah
- Designed to comply with standards: DIN EN 60896-2, DIN 43534, BS 6290, IEC 60896-21/22, IEC 61056
- Extremely low gassing
- Low self discharge
- FAA and IATA approved non-hazardous

Other specifications

Float Design Life @ 25°C:	6-9 Years
Dimensions LxWxH (mm):	165x176x127
Total Height (mm):	127 mm
Operating Temperature:	-20 to 50°C
Separator:	AGM
Grid alloy:	Calcium / Tin lead alloy
Case and lid material:	ABS
Electrolyte:	Sulphuric Acid
Terminal / Lenght:	M5 insert
Optional terminal types:	none
Torque setting:	4-5 Nm
Weight:	7,7 kg (±5%)

Dimensions

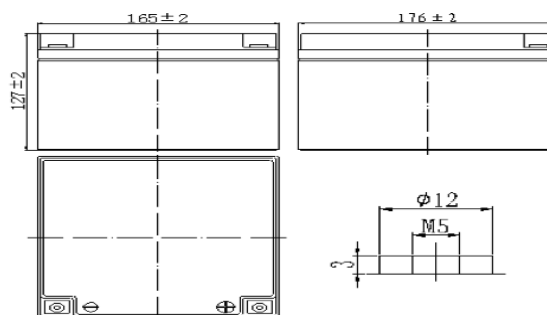

Performance – Current(A) @ 25°C

V/C	5m	10m	15m	20m	25m	30m	35m	40m	45m	50m	55m	60m	90m	2h	3h	4h	5h	6h	7h	8h	9h	10h	12h	20h
1,80	77,7	52,4	42,5	31,9	27,6	24,6	22,3	20,5	18,7	17,4	16,2	15,5	11,5	8,74	6,31	5,04	4,29	3,39	3,04	2,77	2,56	2,37	2,08	1,29
1,75	82,4	55,5	44,9	34,0	29,6	25,6	23,2	21,3	19,4	18,1	16,9	15,9	11,8	8,97	6,50	5,20	4,42	3,50	3,15	2,86	2,63	2,41	2,12	1,30
1,70	86,2	58,1	46,4	34,8	30,2	26,1	23,8	21,8	19,9	18,5	17,3	16,2	12,0	9,10	6,54	5,24	4,45	3,52	3,17	2,87	2,64	2,43	2,13	1,30
1,65	89,6	60,5	48,2	36,1	31,4	27,0	24,5	22,5	20,5	19,1	17,8	16,6	12,2	9,19	6,59	5,27	4,48	3,55	3,20	2,90	2,68	2,44	2,16	1,31
1,60	92,6	62,4	49,4	37,4	32,3	27,6	25,1	23,0	21,0	19,5	18,2	16,9	12,4	9,23	6,63	5,30	4,51	3,56	3,21	2,92	2,69	2,46	2,16	1,31

Performance – Watt per Cell (W/C) @ 25°C

V/C	5m	10m	15m	20m	25m	30m	35m	40m	45m	50m	55m	60m	90m	2h	3h	4h	5h	6h	7h	8h	9h	10h	12h	20h
1,80	143	98,5	80,7	60,5	53,0	47,0	42,6	39,1	36,3	33,8	31,3	29,8	22,3	17,0	12,5	10,0	8,52	6,73	6,05	5,53	5,13	4,75	2,93	2,55
1,75	152	104	85,2	64,5	56,1	48,8	44,3	40,6	37,8	35,1	32,5	30,5	22,8	17,5	12,8	10,3	8,78	6,95	6,25	5,68	5,27	4,83	3,00	2,60
1,70	158	109	88,2	66,2	57,8	50,0	45,5	41,6	38,8	36,1	33,3	31,3	23,3	17,6	12,9	10,4	8,87	7,02	6,32	5,75	5,28	4,87	3,00	2,62
1,65	165	113	91,7	68,7	60,3	51,5	46,8	43,0	40,0	37,1	34,3	32,0	23,6	17,8	13,0	10,4	8,90	7,07	6,37	5,80	5,37	4,88	3,00	2,62
1,60	170	117	93,8	71,0	62,0	52,6	47,8	44,0	40,6	38,0	35,0	32,5	24,0	18,0	13,1	10,5	8,98	7,10	6,40	5,83	5,38	4,92	3,02	2,65



<http://www.wetac.com>

Wetac Stand-By Nederland B.V.
Galvanistraat 117
6716 AE Ede
The Netherlands
+31 318 696 190
orderdesk@wetac.nl

Wetac Stand-By Nederland B.V. OS.
Nadrazni 344/23
150 00 Praha 5
Czech Republic
+420 732 172800
Mail: standby@wetac.com

Wetac Hellas S.A.
7 Neratzoulas Street
13672 Acharnes - Attica
Greece
+30 210 2446 848
info@wetac.gr

Wetac UK Ltd.
Westgate House
44 Hale Road
WA 14 2EX Altrincham - Chesire
United Kingdom
+44 7788 711638
info@wetac.co.uk

BSOL Batteriesysteme GmbH
Bonner Strasse 365
40589 Düsseldorf (Benrath)
Germany
+49 211 387899-40
info@bsol.de

Wetac Swiss GmbH
Weilstrasse 79
4125 Riehen - Basel
Switzerland
+41 61 643 7066
info@wetac.ch

<https://www.facebook.com/wetacbatteries>

<http://linkedin.com/company/wetac-battery-company>

